

BL67 base module

2 × M12 Connector, 8-pin

BL67-B-2M12-8

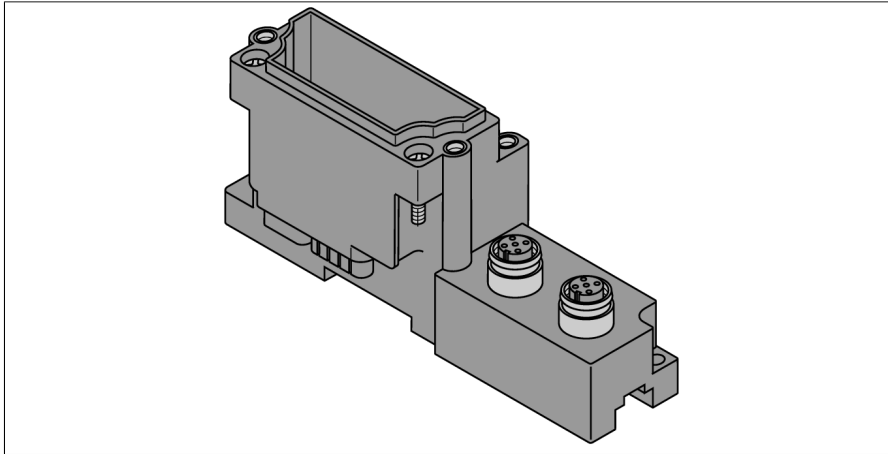

Type	BL67-B-2M12-8
ID	6827336
Housing material	Polycarbonate, flame resistance (PC V0)
Housing color	Gray (RAL 7015)
Tightening torque fixing screw	0.9...1.2 Nm
DIN rail mounting	yes, Attention: Offset
Direct mounting	Two mounting holes, 6
Tightening torque coupling nut sensor plug	0.8...1.0 Nm
Connector A	Female Receptacle, M12 × 1, Threaded
Flange housing	Brass, CuZn, Nickel-plated
Contact carriers	Plastic, TPU, Black
Contacts	Metal, CuZn, Gold-plated
Screw-in thread seal	Plastic, FPM
Insulation resistance	$\geq 10^9 \Omega$
forward resistance	$\leq 5 \text{ m}\Omega$
Pollution degree	3
Number of pins	8
Ampacity	2A
Voltage	30 V
Protection class	IP67, Only when screwed or plugged together
Mechanical lifespan	> 100 Mating cycles

- Passive connection components for sensors and actuators
- Quick replacement of electronics in wired state
- Mechanical coding prevents incorrect electronic modules from being plugged in accidentally
- Protection class IP67
- M12 connection technology
- 8-pin
- 2 slots

Wiring Diagram

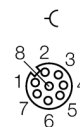

Functional principle

The pin resp. signal assignment results from the combination with an electronic module. You find the pin configuration and the wiring diagrams on the data sheet of the corresponding electronic module.

BL67 base modules are connected to the right of the gateway, using two screws for each module. A DIN rail is not required. This way, a compact and stable unit is built. The unit can now be mounted on a DIN rail or directly on the machine.

The field devices are connected to the base modules which are available with different connection technology (M8, M12, M23 and 7/8").

Note

Further technical data like temperature range are determined by the electronic modules and can be found on the data sheets.