

NIMFE-EM12/4.6L88-UN6X-H1141/S1182

Magnetic Field Sensor – With TIN Coating

For Detection of Ferromagnetic Parts

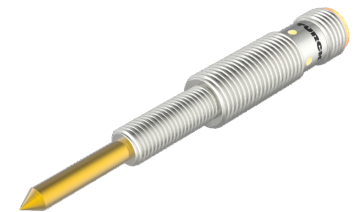
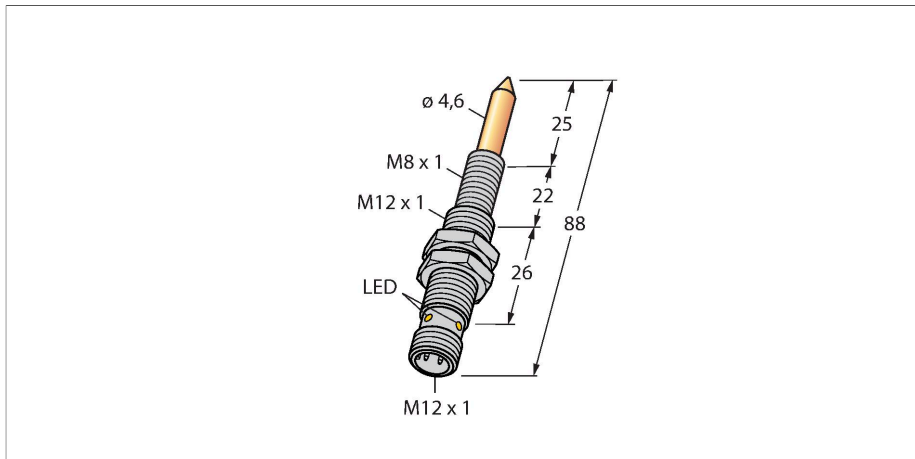

Technical data

Type	NIMFE-EM12/4.6L88-UN6X-H1141/S1182
ID	1600617
Special version	S1182 Corresponds to:TIN coating
General data	
Electrical data	
Operating voltage U_B	10...30 VDC
Ripple U_{ss}	$\leq 10\% U_{Bmax}$
DC rated operating current I_o	$\leq 100\text{ mA}$
No-load current	$\leq 15\text{ mA}$
Residual current	$\leq 0.1\text{ mA}$
Isolation test voltage	0.5 kV
Short-circuit protection	yes/Cyclic
Voltage drop at I_o	$\leq 1\text{ V}$
Wire break/reverse polarity protection	yes/Complete
Output function	3-wire, Connection programmable, NPN
Mechanical data	
Design	Threaded barrel, M12 x 1
Dimensions	88 mm
Housing material	Stainless steel, 1.4301 (AISI 304)
Active area material	Stainless steel, 1.4301 (AISI 304), TIN coating
Max. tightening torque of housing nut	10 Nm
Electrical connection	Connector, M12 x 1
Environmental conditions	
Ambient temperature	-25...+70 °C
Vibration resistance	55 Hz (1 mm)

Features

- Threaded barrel, M12 x 1
- Stainless steel, 1.4301
- DC 3-wire, 10...30 VDC
- NC/NO parametrizable with teach adapter VB2-SP1
- M12 x 1 male connector

Wiring diagram

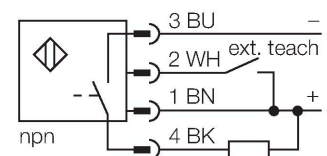

Functional principle

The weld sensors are available in different versions, with different signal intensities and diameters. Ferromagnetic parts which differ strongly in their material properties and diameters can thus be detected. A target part has to be located within the so called sensitive area in order to be detected. The internal sensor signal reaches the maximum intensity if the sensitive area is completely covered by the target. Partial coverage is also possible.

Sensitive area $S = 9\text{ mm}$
 Within this area the sensor signal changes when components are connected.

Maximum range $M = 13\text{ mm}$
 In case of complete coverage of the sensitive area the maximum signal intensity is achieved.

Technical data

Shock resistance	30 g (11 ms)
Protection class	IP67
MTTF	874 years acc. to SN 29500 (Ed. 99) 40 °C
Power-on indication	LED, Green
Switching state	LED, Yellow

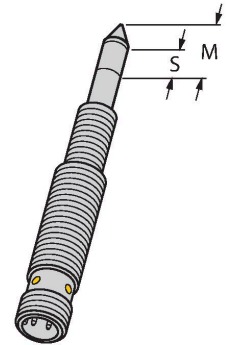

Mounting instructions

Mounting instructions/Description

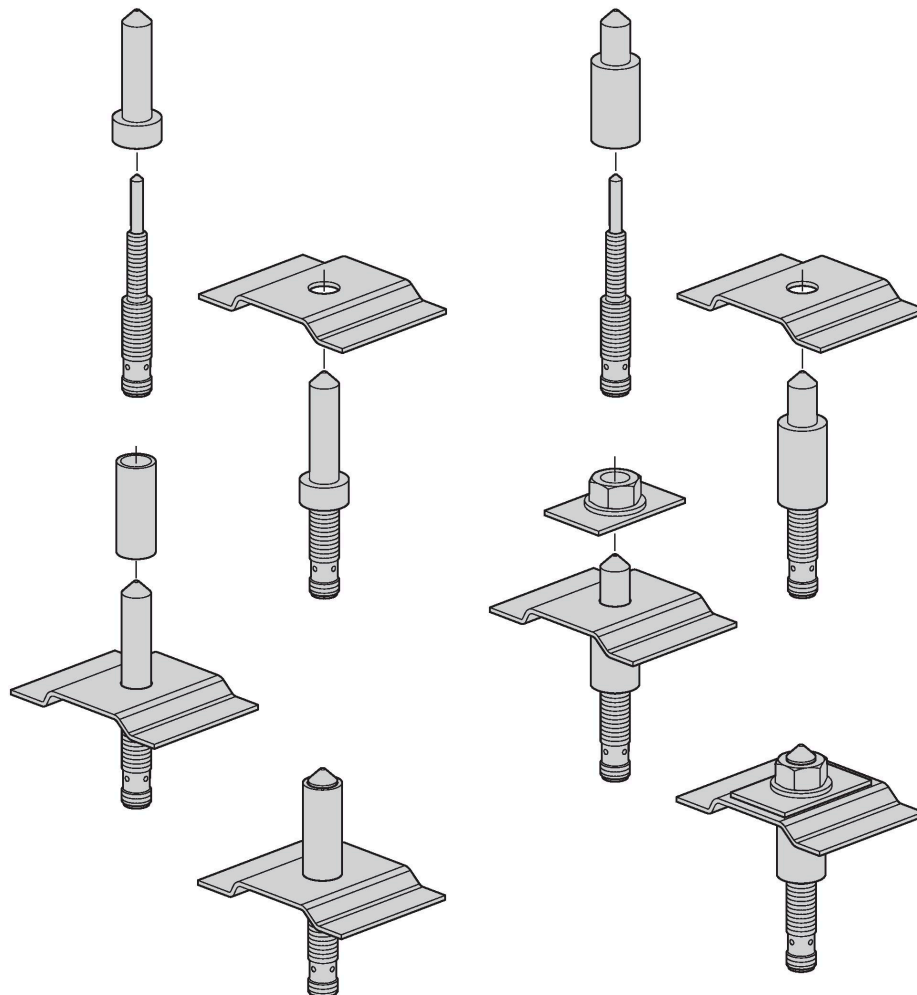

The magnetic field sensor is especially suited for the detection of welding nuts as well as spacer or reinforcing sleeves. The parts to be detected must always consist of ferromagnetic material, so that a proper function can be guaranteed. Most applications need center bolts to tack the welding nuts and reinforcing sleeves in place and thus provide mechanical protection of the sensors. These bolts have to be made of non-ferromagnetic material, like stainless steel for example. Center bolts are not available at Turck, as these have to be individually produced for and adjusted to the correspondent application.

The welding nut sensor detects ferritic targets with diameters between 6 mm and 12 mm.

